

Instruction Manual



TMS PGA PGA370 Hardware Support 071-0475-01

Warning

The servicing instructions are for use by qualified personnel only. To avoid personal injury, do not perform any servicing unless you are qualified to do so. Refer to all safety summaries prior to performing service.

Copyright © Tektronix, Inc. All rights reserved. Licensed software products are owned by Tektronix or its suppliers and are protected by United States copyright laws and international treaty provisions.

Use, duplication, or disclosure by the Government is subject to restrictions as set forth in subparagraph (c)(1)(ii) of the Rights in Technical Data and Computer Software clause at DFARS 252.227-7013, or subparagraphs (c)(1) and (2) of the Commercial Computer Software – Restricted Rights clause at FAR 52.227-19, as applicable.

Tektronix products are covered by U.S. and foreign patents, issued and pending. Information in this publication supercedes that in all previously published material. Specifications and price change privileges reserved.

Printed in the U.S.A.

Tektronix, Inc., P.O. Box 1000, Wilsonville, OR 97070–1000

TEKTRONIX and TEK are registered trademarks of Tektronix, Inc.

HARDWARE WARRANTY

Tektronix warrants that the products that it manufactures and sells will be free from defects in materials and workmanship for a period of one (1) year from the date of shipment. If a product proves defective during this warranty period, Tektronix, at its option, either will repair the defective product without charge for parts and labor, or will provide a replacement in exchange for the defective product.

In order to obtain service under this warranty, Customer must notify Tektronix of the defect before the expiration of the warranty period and make suitable arrangements for the performance of service. Customer shall be responsible for packaging and shipping the defective product to the service center designated by Tektronix, with shipping charges prepaid. Tektronix shall pay for the return of the product to Customer if the shipment is to a location within the country in which the Tektronix service center is located. Customer shall be responsible for paying all shipping charges, duties, taxes, and any other charges for products returned to any other locations.

This warranty shall not apply to any defect, failure or damage caused by improper use or improper or inadequate maintenance and care. Tektronix shall not be obligated to furnish service under this warranty a) to repair damage resulting from attempts by personnel other than Tektronix representatives to install, repair or service the product; b) to repair damage resulting from improper use or connection to incompatible equipment; c) to repair any damage or malfunction caused by the use of non-Tektronix supplies; or d) to service a product that has been modified or integrated with other products when the effect of such modification or integration increases the time or difficulty of servicing the product.

THIS WARRANTY IS GIVEN BY TEKTRONIX IN LIEU OF ANY OTHER WARRANTIES, EXPRESS OR IMPLIED. TEKTRONIX AND ITS VENDORS DISCLAIM ANY IMPLIED WARRANTIES OF MERCHANTABILITY OR FITNESS FOR A PARTICULAR PURPOSE. TEKTRONIX' RESPONSIBILITY TO REPAIR OR REPLACE DEFECTIVE PRODUCTS IS THE SOLE AND EXCLUSIVE REMEDY PROVIDED TO THE CUSTOMER FOR BREACH OF THIS WARRANTY. TEKTRONIX AND ITS VENDORS WILL NOT BE LIABLE FOR ANY INDIRECT, SPECIAL, INCIDENTAL, OR CONSEQUENTIAL DAMAGES IRRESPECTIVE OF WHETHER TEKTRONIX OR THE VENDOR HAS ADVANCE NOTICE OF THE POSSIBILITY OF SUCH DAMAGES.

Table of Contents

General Safety Summary	iii
Service Safety Summary	v
Preface	vii
Manual Conventions	vii
Contacting Tektronix	viii
Getting Started	
Support Package Description	1-1
Support Software Compatibility	1-1
Logic Analyzer Configuration	1-2
Requirements and Restrictions	1-2
Labeling P6434 Probes	1-3
Assembling the Probe Adapter	1-4
Configuring The Probe Adapter	1-6
TIMING/NORMAL Jumper	1-6
MFG_TEST Jumper	1-6
Connecting the Logic Analyzer to a System Under Test	1-7
Alternate Connections	1-12
Applying and Removing Power	1-14
CPU To Mictor Connections	1-17
Specifications	
Circuit Description	2-1
Probe Adapter Loading Diagrams	2-2
Specification Tables	2-5
Maintenance	
Replacing The Fuse	3-1
Replaceable Parts List	
Parts Ordering Information	4-1
Using the Replaceable Parts List	4-1
Index	

List of Figures

Figure 1–1: Seating the 190-pin mictor connector	1–4
Figure 1–2: Attaching the Logic board to the Interposer board	1–5
Figure 1–3: Jumper locations on the PGA370 probe adapter	1–6
Figure 1–4: Connecting a probe to the probe adapter	1–8
Figure 1–5: Sacrificial sockets	1–9
Figure 1–6: Inserting a sacrificial socket into the ZIF socket	1–9
Figure 1–7: Inserting the probe adapter into the sacrificial socket ..	1–10
Figure 1–8: Placing the PGA370 microprocessor into the probe adapter	1–11
Figure 1–9: APIC bus pins location on the probe adapter	1–12
Figure 1–10: Debug port and pin location on the logic board	1–13
Figure 1–11: Test point location on the probe adapter	1–14
Figure 1–12: Location of the power jack	1–15
Figure 1–13: Pin assignments for a Mictor connector (component side)	1–17
Figure 2–1: PGA370 signals without active loads	2–2
Figure 2–2: PGA370 signals with active loads	2–2
Figure 2–3: PGA370 BCLK	2–2
Figure 2–4: Detail of PGA370 sockets and 190-pin mictor connector.	2–3
Figure 2–5: Equivalent circuit for the P6434 probe	2–4
Figure 2–6: Dimensions of the PGA370 probe adapter	2–7
Figure 3–1: Fuse location on the PGA370 probe adapter	3–1
Figure 4–1: PGA370 probe adapter exploded view	4–6

List of Tables

Table 1–1: APIC information	1–12
Table 1–2: Jumper (J510) information	1–13
Table 1–3: Test point (J700) information	1–14
Table 1–4: Clock Channels (stored in the acquisition memory)	1–17
Table 1–5: Qualifier Channels (stored in the acquisition memory) ..	1–18
Table 1–6: CPU to Mictor connections for Mictor C pins (high)	1–18
Table 1–7: CPU to Mictor connections for Mictor A pins (high)	1–19
Table 1–8: CPU to Mictor connections for Mictor D pins (high)	1–20
Table 1–9: CPU to Mictor connections for Mictor C pins (Low)	1–21
Table 1–10: CPU to Mictor connections for Mictor A pins (Low) ...	1–23
Table 1–11: CPU to Mictor connections for Mictor D pins (Low) ...	1–24
Table 2–1: Lossy delay line values	2–4
Table 2–2: Electrical specifications for the system under test	2–5
Table 2–3: Electrical specifications for the AC adapter	2–6
Table 2–4: Environmental specifications	2–6
Table 2–5: BCLK timing and electrical specifications	2–6

General Safety Summary

Review the following safety precautions to avoid injury and prevent damage to this product or any products connected to it. To avoid potential hazards, use this product only as specified.

Only qualified personnel should perform service procedures.

While using this product, you may need to access other parts of the system. Read the *General Safety Summary* in other system manuals for warnings and cautions related to operating the system.

To Avoid Fire or Personal Injury

Use Proper Power Cord. Use only the power cord specified for this product and certified for the country of use.

Connect and Disconnect Properly. Do not connect or disconnect probes or test leads while they are connected to a voltage source.

Ground the Product. This product is indirectly grounded through the grounding conductor of the mainframe power cord. To avoid electric shock, the grounding conductor must be connected to earth ground. Before making connections to the input or output terminals of the product, ensure that the product is properly grounded.

Observe All Terminal Ratings. To avoid fire or shock hazard, observe all ratings and marking on the product. Consult the product manual for further ratings information before making connections to the product.

The common terminal is at ground potential. Do not connect the common terminal to elevated voltages.

Do not apply a potential to any terminal, including the common terminal, that exceeds the maximum rating of that terminal.

Use Proper AC Adapter. Use only the AC adapter specified for this product.

Do Not Operate Without Covers. Do not operate this product with covers or panels removed.

Use Proper Fuse. Use only the fuse type and rating specified for this product.

Avoid Exposed Circuitry. Do not touch exposed connections and components when power is present.

Do Not Operate With Suspected Failures. If you suspect there is damage to this product, have it inspected by qualified service personnel.

Do Not Operate in Wet/Damp Conditions.

Do Not Operate in an Explosive Atmosphere.

Keep Product Surfaces Clean and Dry.

Provide Proper Ventilation. Refer to the manual's installation instructions for details on installing the product so it has proper ventilation.

Symbols and Terms

Terms in this Manual. These terms may appear in this manual:



WARNING. Warning statements identify conditions or practices that could result in injury or loss of life.



CAUTION. Caution statements identify conditions or practices that could result in damage to this product or other property.

Terms on the Product. These terms may appear on the product:

DANGER indicates an injury hazard immediately accessible as you read the marking.

WARNING indicates an injury hazard not immediately accessible as you read the marking.

CAUTION indicates a hazard to property including the product.

Symbols on the Product. The following symbols may appear on the product:



WARNING
High Voltage



Protective Ground
(Earth) Terminal



CAUTION
Refer to Manual



Double
Insulated

Service Safety Summary

Only qualified personnel should perform service procedures. Read this *Service Safety Summary* and the *General Safety Summary* before performing any service procedures.

Do Not Service Alone. Do not perform internal service or adjustments of this product unless another person capable of rendering first aid and resuscitation is present.

Disconnect Power. To avoid electric shock, switch off the instrument power, then disconnect the power cord from the mains power.

Use Care When Servicing With Power On. Dangerous voltages or currents may exist in this product. Disconnect power, remove battery (if applicable), and disconnect test leads before removing protective panels, soldering, or replacing components.

To avoid electric shock, do not touch exposed connections.

Preface

This instruction manual contains specific information about the TMS PGA PGA370 microprocessor support package and is part of a set of information on how to operate this product on compatible Tektronix logic analyzers.

If you are familiar with operating microprocessor support packages on the logic analyzer for which the TMS PGA PGA370 support was purchased, you will only need this instruction manual to set up and run the support.

If you are not familiar with operating microprocessor support packages, you will need to supplement this instruction manual with information on basic operations to set up and run the support.

This manual provides detailed information on the following topics:

- Assembling and configuring the probe adapter
- Connecting the logic analyzer to the system under test
- Applying power and operating the probe adapter

Manual Conventions

This manual uses the following conventions:

- The term “module” refers to two 102-channel modules, a 102-channel module plus a 136-channel module, or two 136-channel modules.
- A pound sign (#) following a signal name indicates an active low signal.
- The phrase “information on basic operations” refers to basic information in your online help.
- The term “HI module” refers to the module in the higher-numbered slot and the term “LO module” refers to the module in the lower-numbered slot.

Contacting Tektronix

Product Support	<p>For questions about using Tektronix measurement products, call toll free in North America: 1-800-TEK-WIDE (1-800-835-9433 ext. 2400) 6:00 a.m. – 5:00 p.m. Pacific time</p> <p>Or contact us by e-mail: tm_app_supp@tektronix.com</p> <p>For product support outside of North America, contact your local Tektronix distributor or sales office.</p>
Service Support	<p>Tektronix offers extended warranty and calibration programs as options on many products. Contact your local Tektronix distributor or sales office.</p> <p>For a listing of worldwide service centers, visit our web site.</p>
For other information	<p>In North America: 1-800-TEK-WIDE (1-800-835-9433) An operator will direct your call.</p>
To write us	<p>Tektronix, Inc. P.O. Box 1000 Wilsonville, OR 97070-1000 USA</p>
Website	<p>Tektronix.com</p>



Getting Started

Getting Started

This chapter contains information on the TMS PGA PGA370 hardware support product, and information on connecting your logic analyzer to your system under test.

Support Package Description

The PGA370 probe adapter is nonintrusive hardware that allows the logic analyzer to acquire data from a microprocessor in its own operating environment with little effect on that system.

The PGA370 probe adapter is an interposer design. The probe adapter connects to the system under test, and then the microprocessor connects to the probe adapter. Signals from the microprocessor-based system flow through the probe adapter into the P6434 probes and through the probe cables to the logic analyzer.

Support Software Compatibility

The PGA370 probe adapter is compatible with software products that provide timing analysis capabilities, and synchronous transactions and instruction decode. These support software are only available to customers with a valid restricted secret nondisclosure agreement (RS-NDA) with Intel.

At the time of printing, the compatible software support product is the TMS113. When using the PGA370 probe adapter with the TMS113 software, choose any one of the PG370 custom clocking options.

However, for customers without RS-NDAs, Tektronix offers a basic clocking software for the PGA370 probe adapter at no cost. This clocking software allows customers to conduct timing analysis by predefining channel assignments and configuring the logic analyzer to acquire all bus cycles. Contact your Tektronix representative to obtain this complementary software or to determine which latest software support products are compatible with the TMS PGA PGA370 product.

Logic Analyzer Configuration

To use the TMS PGA PGA370 hardware support package you need a Tektronix logic analyzer equipped with two 102-channel modules. The modules must be in adjacent slots and merged.

References to a 204-channel module include the two 102-channel modules that are merged and any other merged module combination of a minimum of 204-channels (for the merged combination).

You can acquire Debug and APIC bus activity through the PGA370 probe adapter. Probing the APIC bus requires the TMS 801 APIC bus support package, a third 102-channel acquisition module, and standard probes. See *Alternate Connections* on page 1–12 for more details.

Requirements and Restrictions



CAUTION. *Forced air cooling must be used to keep the microprocessor from overheating.*

You should review the general requirements and restrictions of microprocessor support packages in the information on basic operations as they pertain to your system under test.

You should also review electrical, environmental, and mechanical specifications in *Specifications* on page 2–1 as they pertain to your system under test, as well as the following descriptions of other TMS PGA PGA370 hardware support requirements and restrictions.

System Clock Rate

The TMS PGA PGA370 microprocessor support can acquire data from the PGA370 microprocessors operating at speeds of up to 100 MHz; the microprocessor support has been tested to 100 MHz.

The operating clock rate specifications were measured at the time of printing. Contact your Tektronix sales representative for current information on the fastest devices supported.

BCLK

Refer to the BCLK specifications and restrictions listed in Table 2–5 on page 2–6, in the *Specifications* chapter.

System Under Test Power

Whenever you power off the system under test, remove power from the probe adapter. Refer to *Applying and Removing Power* on page 1–14.

Signals Supported

The following signals are supported by the PGA370 probe adapter:

A[31:3]#	FLUSH#	RS[2:0]#
A20M#	HIT#	SLP#
ADS#	HITM#	SMI#
BCLK	IERR#	STPCLK#
BNR#	IGNNE#	TCK
BP[3:2]#	INIT#	TDI
BPM[1:0]#	LINT[1:0]	TDO
BPRI#	LOCK#	THERMDN
BR0#	PICCLK	THERMDP
BSEL#	PICD[1:0]	THERMTRIP#
D[63:0]#	PRDY#	TMS
DBSY#	PREQ#	TRDY#
DEFER#	PWRGOOD	TRST#
DRDY#	REQ[4:0]#	
FERR#	RESET#	

Labeling P6434 Probes

The TMS PGA PGA370 hardware support package relies on the standard channel mapping and labeling scheme for P6434 probes. Apply labels using the standard method described in the *P6434 Mass Termination Probe Instructions*.

Assembling the Probe Adapter

The probe adapter assembly consists of a Logic board, Interposer board, and screws.



CAUTION. Static discharge can damage the microprocessor, the probe adapter, the probes, and the module. To prevent static damage, handle components only in a static-free environment.

Always wear a grounding wrist strap, heel strap, or similar device while handling the microprocessor and probe adapter.

Do the following steps to assemble the probe adapter:

1. To discharge any static electricity, touch the ground connector located on the logic analyzer. Then, before you remove the probe adapter circuit boards from their protective bags, touch each bag to discharge stored static electricity.
2. Align the Logic board connector pins with the Interposer board connector pins, and press firmly to seat the board connector (see Figure 1–1). Both connectors are polarized and will only mate in one orientation.

NOTE. To ensure a reliable electrical connection between the Logic board and the Interposer board the 190-pin mictor connector must be completely seated at both ends (see Figure 1–1).

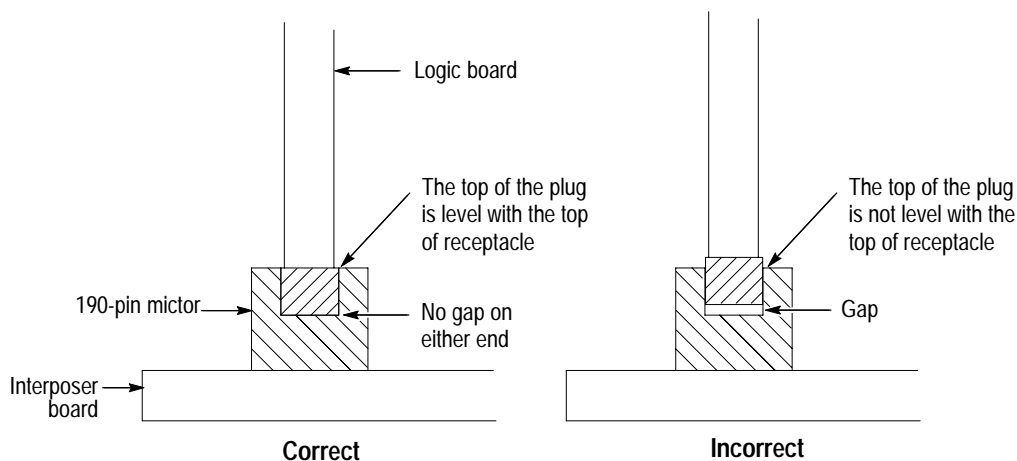

Figure 1–1: Seating the 190-pin mictor connector

3. Align the mounting brackets on the logic board with the mounting holes on the interposer board (see Figure 1–2).
4. Attach and tighten the screws (see Figure 1–2).
5. Remove the sacrificial socket from the bottom of the Interposer board. This socket was installed to protect the pins during shipping. Retain this socket to use later with the PGA370 probe adapter for timing and disassembly support.

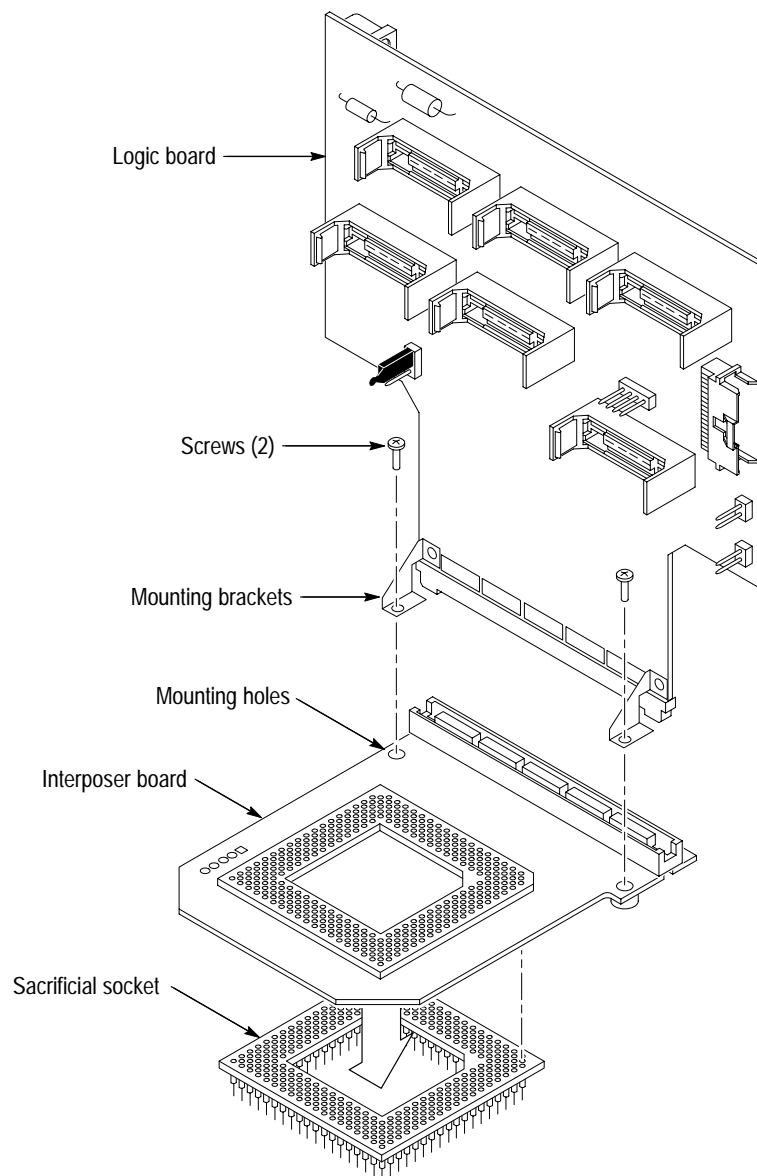

Figure 1–2: Attaching the Logic board to the Interposer board

Configuring The Probe Adapter

The probe adapter uses jumpers to acquire data for disassembly or for timing. Figure 1–3 shows the location of the jumpers.

TIMING/NORMAL Jumper

Place the TIMING/NORMAL jumper, J600, in the NORMAL position to acquire and disassemble data.

Place the TIMING/NORMAL jumper in the TIMING position to acquire timing data.

Figure 1–3 shows the location of J600 on the probe adapter.

MFG_TEST Jumper

To acquire data at frequencies below 40 MHz on the probe adapter, short the two pins on J512. This disables the PLL signal and buffers the BCLK signal to all clocked components.

Figure 1–3 shows the location of J512 on the probe adapter.

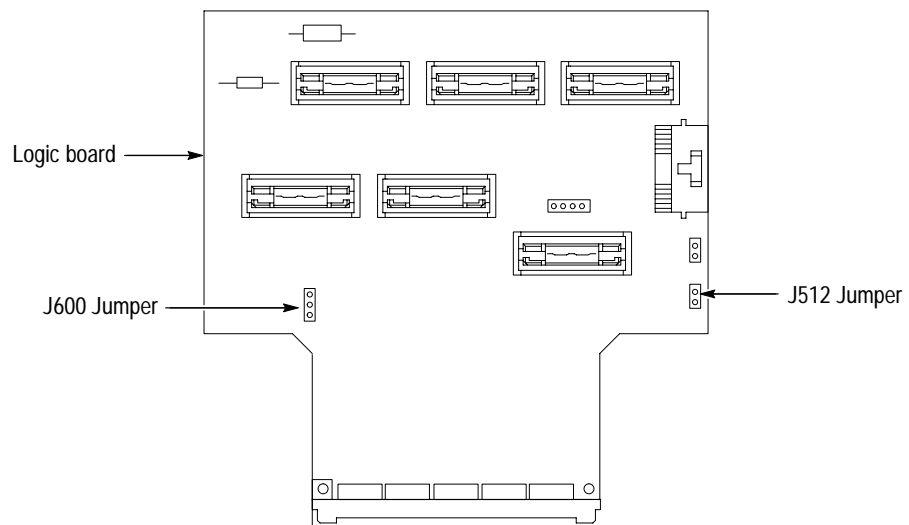

Figure 1–3: Jumper locations on the PGA370 probe adapter

Connecting the Logic Analyzer to a System Under Test

Before you connect the probe adapter to the system under test, connect three P6434 probes to the HI module and three P6434 probes to the LO module. The module in the higher-numbered slot is referred to as the HI module and the module in the lower-numbered slot is referred to as the LO module.

Your system under test must allow clearance for the probe adapter. Refer to the dimensions on page 2–7 for the required clearances.

To connect the logic analyzer to your system under test, follow these steps:

1. Power off your system under test. It is not necessary to power off the logic analyzer.



CAUTION. *Static discharge can damage the microprocessor, the probe adapter, the probes, and the module. To prevent static damage, handle the components only in a static-free environment.*

Always wear a grounding wrist strap, heel strap, or similar device while handling the microprocessor and probe adapter.

2. Match the A, C, and D probes from the HI module with the corresponding HI_A, HI_C, and HI_D probe connectors on the probe adapter. Align the pin 1 indicator on the probe label with the pin 1 indicator of the connector on the probe adapter.



CAUTION. *Incorrect handling of the P6434 probe while connecting it to the probe adapter can result in damage to the probe or to the mating connector on the probe adapter. To avoid damaging the probe and probe adapter, always position the probe perpendicular to the mating connector and gently connect the probe.*

3. Position the probe tip perpendicular to the mating connector and gently connect the probe (see Figure 1–4).
4. When connected, push down the latch releases on the probe to set the latch.

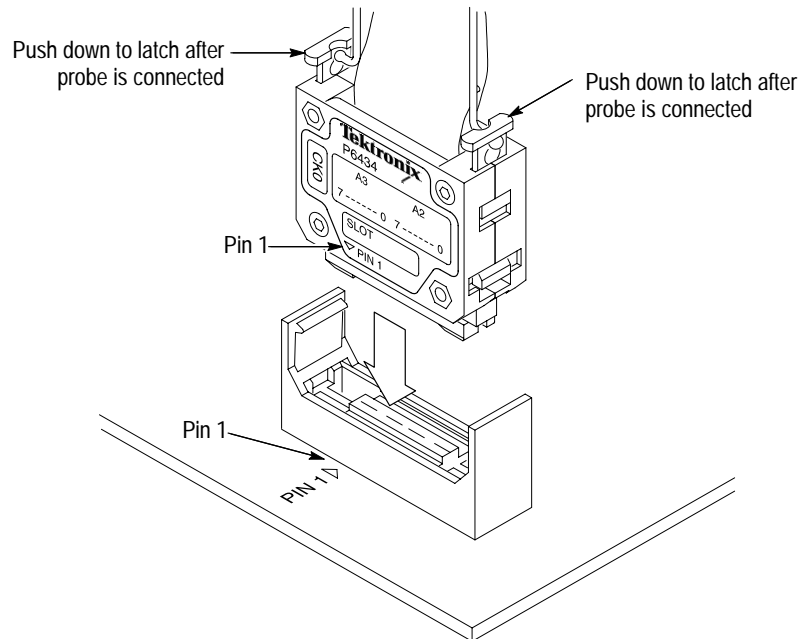

Figure 1-4: Connecting a probe to the probe adapter

5. Match the A, C, and D probes from the LO module with the corresponding LO_A, LO_C, and LO_D probe connectors on the probe adapter. Align the pin 1 indicator on the probe label with pin 1 of the connector on the probe adapter.
6. Repeat steps 3 and 4.
7. Follow the procedure from the PGA370 microprocessor vendor to remove the microprocessor from the PGA370 socket on your system under test.
8. Choose the correct sacrificial socket.

When using the PGA370 probe adapter for timing and disassembly support, choose the 370-pin sacrificial socket. When using the PGA370 probe adapter for a debugging port, choose the 363-pin sacrificial socket.

NOTE. Use one sacrificial socket at a time. Do not install a sacrificial socket without removing all existing sockets from the system under test and from the bottom of the probe adapter assembly.

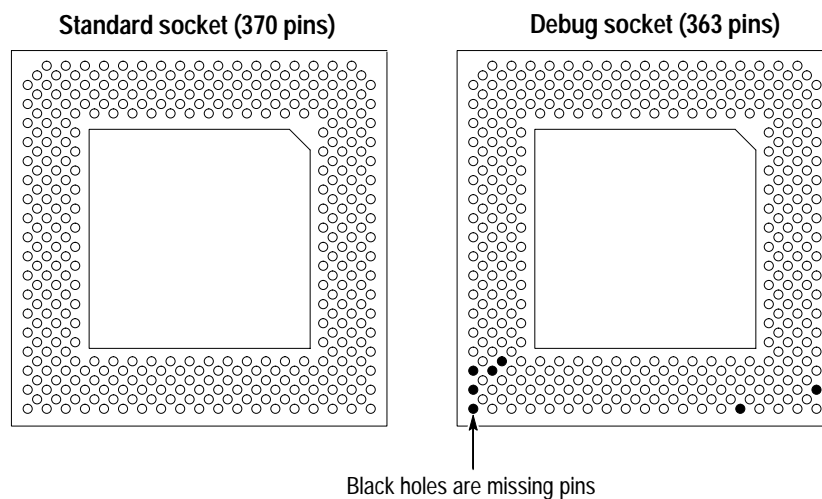

Figure 1-5: Sacrificial sockets

9. Align the A3 pin indicator on the sacrificial socket with pin A3 of the PGA370 socket on your system under test.
10. Insert the sacrificial socket into the system under test as shown in Figure 1-6.

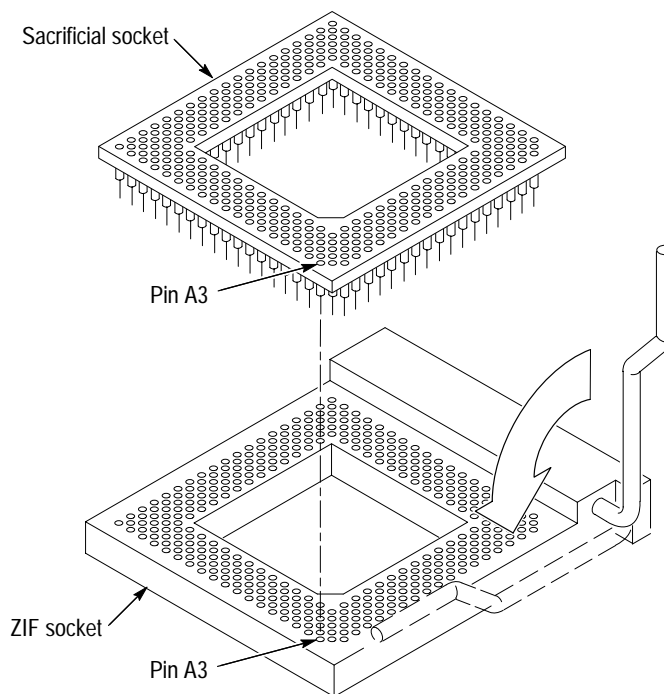

Figure 1-6: Inserting a sacrificial socket into the ZIF socket

11. Align the A3 pin indicator on the probe adapter with the A3 pin indicator on the installed sacrificial socket.
12. Insert the probe adapter into the installed sacrificial socket as shown in Figure 1–7.

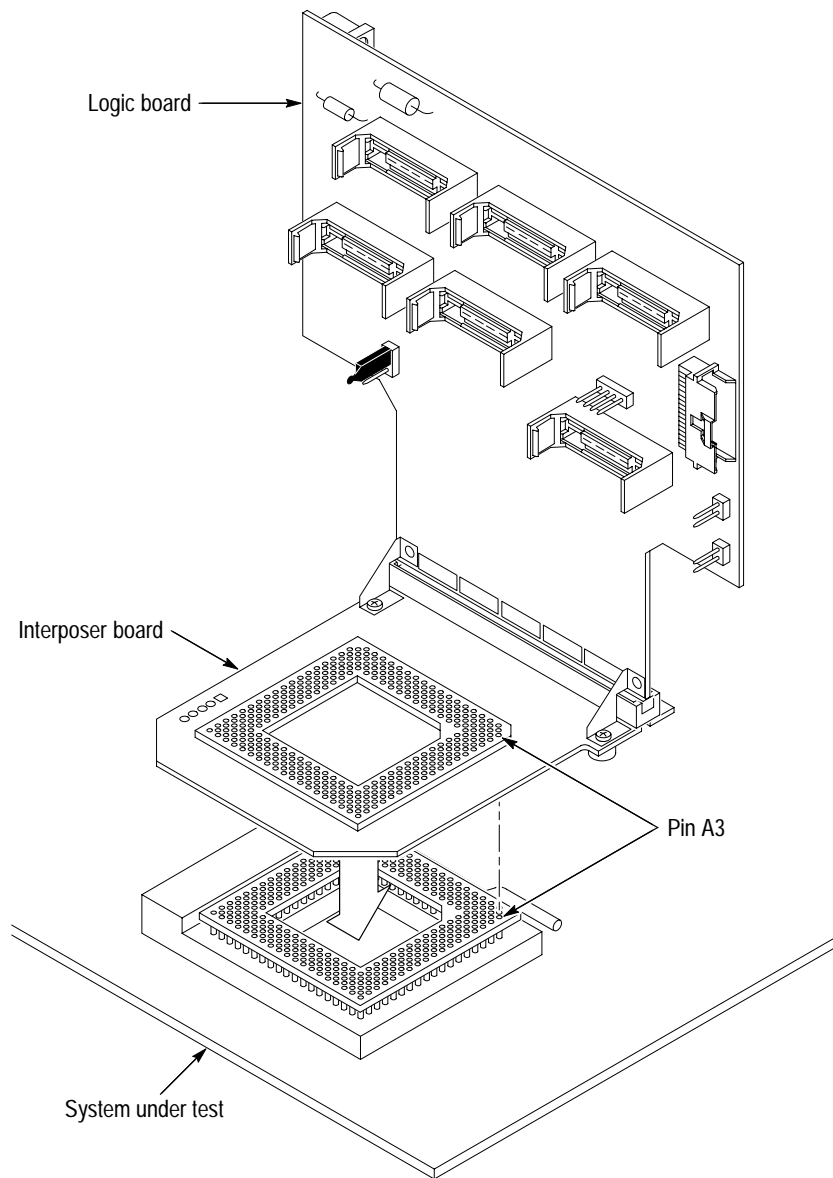

Figure 1–7: Inserting the probe adapter into the sacrificial socket

13. Insert the microprocessor into the probe adapter as shown in Figure 1–8.

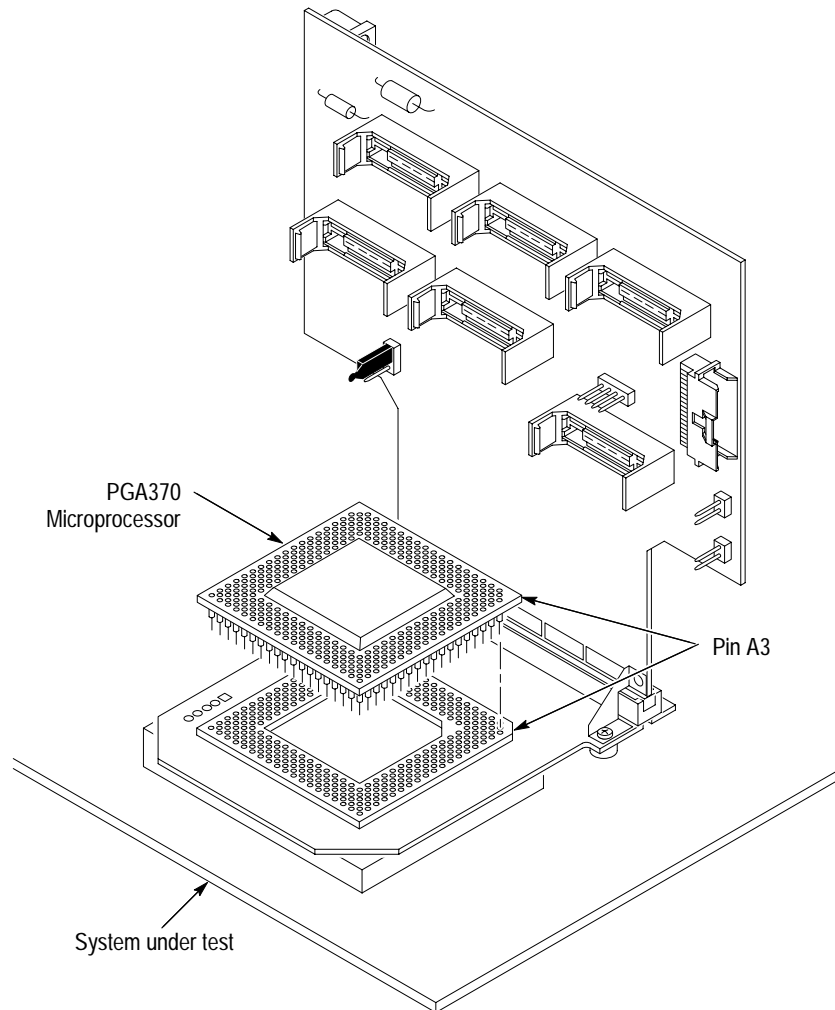

Figure 1–8: Placing the PGA370 microprocessor into the probe adapter

14. Apply forced air cooling across the PGA370 microprocessor to keep the microprocessor from overheating.

Alternate Connections

APIC Four pins on J410 are provided to connect the TMS 801 APIC bus probe adapter to the PICCLK, PICD0 and PICD1 signals for APIC bus support. The TMS 801 APIC bus probe adapter is not included with the TMS PGA PGA370 hardware support package. Contact a Tektronix representative for information on how to obtain the TMS 801 APIC bus probe adapter.

Figure 1–9 shows the APIC bus signal pins for the PGA370 probe adapter.

Table 1–1: APIC information

J410 pin number	Microprocessor pin number	Microprocessor signal name
1	GND	---
2	J33	PICCLK
3	L35	PICD1
4	J35	PICD0

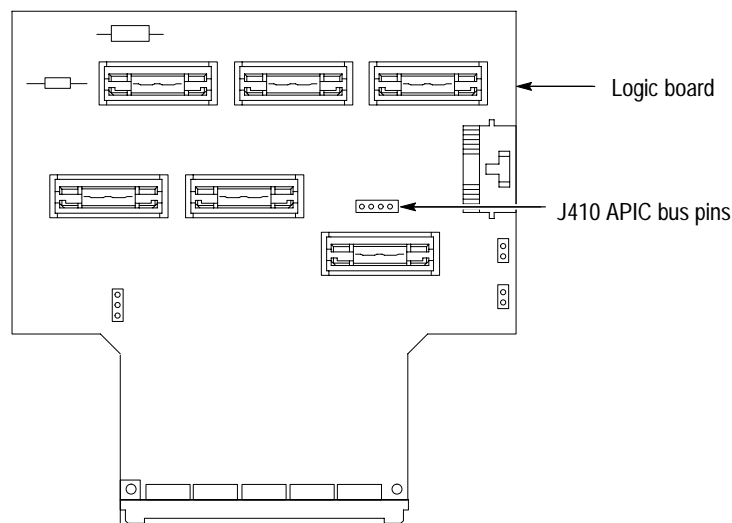

Figure 1–9: APIC bus pins location on the probe adapter

Debug Port The PGA370 probe adapter provides J310 as a way to connect to JTAG Run Control debugging hardware. This Run Control hardware is not included with the TMS PGA PGA370 hardware support package. Contact your microprocessor vendor for information on how to obtain Run Control debugging tools.

NOTE. The debug circuitry on the Logic board is active only when the debug probe cable is connected to J310. If the debug probe cable is disconnected from J310, all debug data and control lines on the logic board are tristated.

Optional System Reset. The Debug port circuitry on the Interposer board does not allow external debugging hardware to induce a system reset through the DBRESET# signal on the Debug port connector. If you need to enable this feature you must provide the connection to your system under test. The following Table 1–2 lists the signals on the J510.

Table 1–2: Jumper (J510) information

Pin number	Debug port signal name
1	GND
2	DBRESET#

Figure 1–10 shows the location of the DBRESET# jumper and Debug port on the logic board of the probe adapter.

When using debugging hardware with the PGA370 probe adapter, a special 363-pin sacrificial socket must be installed in the system under test. See *Connecting the Logic Analyzer to a System Under Test* on page 1–7 for further information.

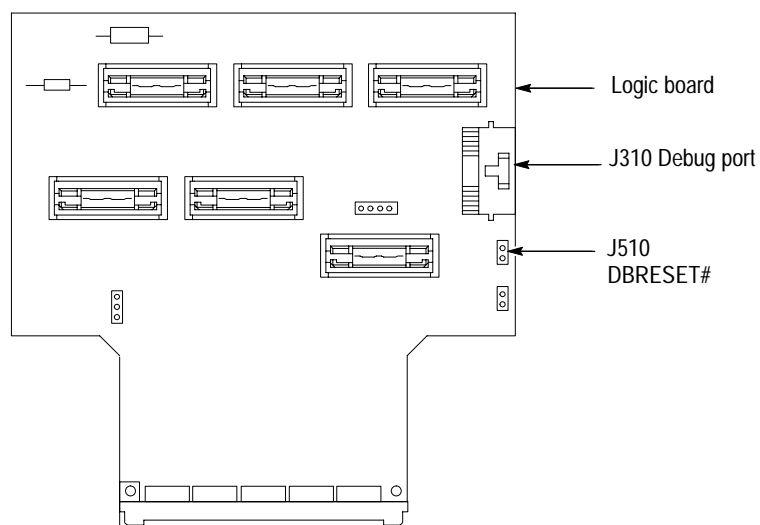

Figure 1–10: Debug port and pin location on the logic board

Test Points Additional test points on the Interposer board at J700 allow alternate ways of probing for information as shown on Figure 1–11. Table 1–3 lists the signals on J700.

Table 1–3: Test point (J700) information

J700 pin number	PGA370 microprocessor pin	PGA370 microprocessor signal
1	AJ33	BSEL#
2	AJ31	Reserved
3	AL31	THERMDP
4	AL29	THERMDN
5	---	GND

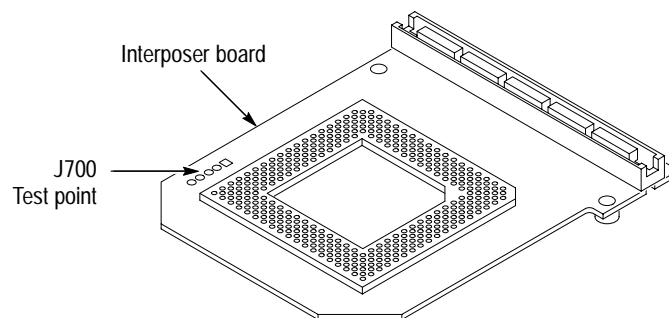

Figure 1–11: Test point location on the probe adapter

Applying and Removing Power

A power supply for the PGA370 probe adapter is included with this TMS PGA PGA370 hardware support. The power supply provides +5 volts power to the probe adapter.

NOTE. Whenever you power off the system under test, be sure to remove power from the probe adapter.

To apply power to the PGA370 probe adapter and system under test, follow these steps:



CAUTION. Failure to use the +5 V power supply provided by Tektronix can permanently damage the probe adapter and PGA370 microprocessor. Do not mistake another power supply that looks similar for the +5 V power supply.

1. Connect the +5 V power supply to the jack on the probe adapter. Figure 1–12 shows the location of the jack on the adapter board.



CAUTION. Failure to apply power to the probe adapter before applying power to your system under test can permanently damage the PGA370 microprocessor and system under test.

2. Plug the power supply for the probe adapter into an electrical outlet. When power is present on the probe adapter, an LED lights near the power jack.
3. Power on the system under test.

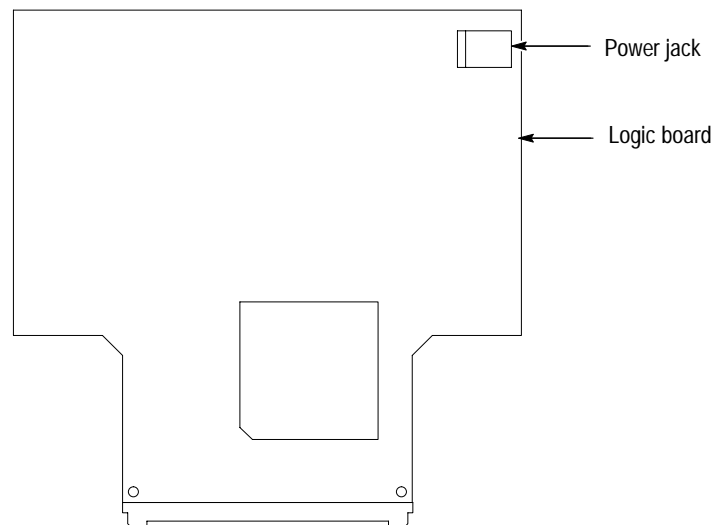

Figure 1–12: Location of the power jack

To remove power from the system under test and the probe adapter, follow these steps:



CAUTION. *Failure to power down your system under test before removing the power from the probe adapter can permanently damage the PGA370 microprocessor and the system under test.*

1. Power off the system under test.
2. Unplug the power supply for the probe adapter from the electrical outlet.

CPU To Mictor Connections

To probe the microprocessor, you will need to make connections between the CPU and the Mictor pins of the P6434 Mass Termination Probe. Refer to the *P6434 Mass Termination Probe* manual, Tektronix part number 070-9793-XX, for more information on mechanical specifications. Tables 1–4 through 1–11 show the CPU pin to Mictor pin connections.

Tektronix uses a counterclockwise pin assignment. Pin 1 is located at the top left, and pin 2 is located directly below it. Pin 20 is located on the bottom right, and pin 21 is located directly above it (see Figure 1–13).

AMP uses an odd side-even side pin assignment. Pin 1 is located at the top left, and pin 3 is located directly below it. Pin 2 is located on the top right, and pin 4 is located directly below it (see Figure 1–13).

NOTE. When designing Mictor connectors into your system under test, always follow the Tektronix pin assignment.

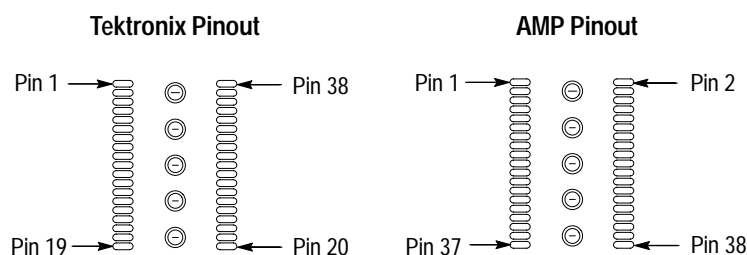

Figure 1–13: Pin assignments for a Mictor connector (component side)

Table 1–4: Clock Channels (stored in the acquisition memory)

Clock channel	CLK, QUAL, or DATA	Active CLK edge	Processor pin name	Processor pin number
LO_CLK:3	CLK	Rising	BCLK	W37
LO_CLK:2	DATA	X	--	--
LO_CLK:1	DATA	X	--	--
LO_CLK:0	--	X	--	--
HI_CLK:3	DATA	X	--	--
HI_CLK:2	DATA	X	--	--
HI_CLK:1	DATA	X	--	--
HI_CLK:0	--	X	--	--

Table 1–5: Qualifier Channels (stored in the acquisition memory)

QUAL channel	QUAL, or DATA	Active CLK edge	Processor pin name	Processor pin number
LO_QUAL:3	--	Rising	--	--
LO_QUAL:2	--	X	--	--
LO_QUAL:1	DATA	X	Reserved	AL21
LO_QUAL:0	DATA	X	Reserved	G37
HI_QUAL:3	--	X	--	--
HI_QUAL:2	--	X	--	--
HI_QUAL:1	DATA	X	Reserved	AN21
HI_QUAL:0	DATA	X	Reserved	F10

NOTE. Dashes — indicates: the CLK or QUAL channel is not used, the channel is not supported by the support software, or the channel is not connected to the microprocessor.

CLK and QUAL channels designated as DATA are logged in on the master strobe defined by the support software.

Table 1–6: CPU to Mictor connections for Mictor C pins (high)

Tektronix Mictor A pin number	AMP Mictor A pin number	LA channel	Processor pin name	Processor pin number
4	7	C3:7	FLUSH#	AE37
8	15	C3:3	Reserved	C33
12	23	C2:7	Reserved	A31
16	31	C2:3 ¹	RESET#	X4
5	9	C3:6	INIT#	AG33
9	17	C3:2	Reserved	A33
13	25	C2:6	Reserved	A29
17	33	C2:2 ¹	Reserved	AK16
6	11	C3:5	PRDY#	A35
10	19	C3:1	Reserved	C31
14	27	C2:5	Reserved	C29
18	35	C2:1 ¹	BREQ0#	AN29
7	13	C3:4	Not Specified	Not Specified
11	21	C3:0	Not Specified	Not Specified

Table 1–6: CPU to Mictor connections for Mictor C pins (high) (cont.)

Tektronix Mictor A pin number	AMP Mictor A pin number	LA channel	Processor pin name	Processor pin number
15	29	C2:4	Not Specified	Not Specified
19	37	C2:0 ¹	Derived	Derived
35	8	C1:7	Derived	Derived
31	16	C1:3	Derived	Derived
27	24	C0:7	Derived	Derived
23	32	C0:3	Not Specified	Not Specified
34	10	C1:6	Derived	Derived
30	18	C1:2	Derived	Derived
26	26	C0:6	Derived	Derived
22	34	C0:2	Derived	Derived
33	12	C1:5	SLP#	AH30
29	20	C1:1	Derived	Derived
25	28	C0:5	Derived	Derived
21	36	C0:1	Derived	Derived
32	14	C1:4	Derived	Derived
28	22	C1:0	Derived	Derived
24	30	C0:4	Derived	Derived
20	38	C0:0	PWRGOOD	AK26

Table 1–7: CPU to Mictor connections for Mictor A pins (high)

Tektronix Mictor A pin number	AMP Mictor A pin number	LA channel	Processor pin name	Processor pin number
4	7	A3:7	D62#	E25
5	9	A3:6	D61#	A27
6	11	A3:5	D55#	C19
7	13	A3:4	D60#	A25
8	15	A3:3	D53#	A23
9	17	A3:2	D57#	A19
10	19	A3:1	D46#	A21
11	21	A3:0	D49#	C13

Table 1-7: CPU to Mictor connections for Mictor A pins (high) (cont.)

Tektronix Mictor A pin number	AMP Mictor A pin number	LA channel	Processor pin name	Processor pin number
12	23	A2:7	D51#	A13
13	25	A2:6	D42#	D12
14	27	A2:5	D45#	C11
15	29	A2:4	D39#	D10
16	31	A2:3	D40#	C15
17	33	A2:2	D34#	C7
18	35	A2:1	D38#	D8
19	37	A2:0	D32#	F6
35	8	A1:7	D58#	C23
34	10	A1:6	D63#	F16
33	12	A1:5	D56#	C27
32	14	A1:4	D50#	C25
31	16	A1:3	D54#	C21
30	18	A1:2	D59#	C17
29	20	A1:1	D48#	A17
28	22	A1:0	D52#	D16
27	24	A0:7	D41#	D14
26	26	A0:6	D47#	A15
25	28	A0:5	D44#	A11
24	30	A0:4	D36#	C9
23	32	A0:3	D43#	A7
22	34	A0:2	D37#	A9
21	36	A0:1	D33#	C1
20	38	A0:0	D35#	B2

Table 1-8: CPU to Mictor connections for Mictor D pins (high)

Tektronix Mictor A pin number	AMP Mictor A pin number	LA channel	Processor pin name	Processor pin number
4	7	D3:7	D28#	A5
5	9	D3:6	D29#	A3
6	11	D3:5	D26#	E1
7	13	D3:4	D25#	E3
8	15	D3:3	D22#	F8

Table 1-8: CPU to Mictor connections for Mictor D pins (high) (cont.)

Tektronix Mictor A pin number	AMP Mictor A pin number	LA channel	Processor pin name	Processor pin number
9	17	D3:2	D19#	H6
10	19	D3:1	D18#	P4
11	21	D3:0	D20#	L3
12	23	D2:7	D17#	R4
13	25	D2:6	D15#	U3
14	27	D2:5	D12#	Q1
15	29	D2:4	D7#	J1
16	31	D2:3	D6#	T6
17	33	D2:2	D5#	S3
18	35	D2:1	D3#	M6
19	37	D2:0	D1#	T4
35	8	D1:7	D31#	C5
34	10	D1:6	D30#	J3
33	12	D1:5	D27#	F12
32	14	D1:4	D24#	K6
31	16	D1:3	D23#	G3
30	18	D1:2	D21#	G1
29	20	D1:1	D16#	H4
28	22	D1:0	D13#	L1
27	24	D0:7	D11#	M4
26	26	D0:6	D10#	Q3
25	28	D0:5	D14#	N3
24	30	D0:4	D9#	P6
23	32	D0:3	D8#	S1
22	34	D0:2	D4#	U1
21	36	D0:1	D2#	N1
20	38	D0:0	D0#	W1

Table 1-9: CPU to Mictor connections for Mictor C pins (Low)

Tektronix Mictor A pin number	AMP Mictor A pin number	LA channel	Processor pin name	Processor pin number
4	7	C3:7	Reserved	AN11
8	15	C3:3	Reserved	AN23

Table 1-9: CPU to Mictor connections for Mictor C pins (Low) (cont.)

Tektronix Mictor A pin number	AMP Mictor A pin number	LA channel	Processor pin name	Processor pin number
12	23	C2:7	Reserved	AN13
16	31	C2:3 ¹	Reserved	AL11
5	9	C3:6	BNR#	AH14
9	17	C3:2	LOCK#	AK20
13	25	C2:6	DBSY#	AL27
17	33	C2:2 ¹	Reserved	AK24
6	11	C3:5	BPRI#	AN17
10	19	C3:1	DRDY#	AN27
14	27	C2:5	RS2#	AK28
18	35	C2:1 ¹	ADS#	AN31
7	13	C3:4	Reserved	AL13
11	21	C3:0	Reserved	AN15
15	29	C2:4	Not Specified	Not Specified
19	37	C2:0 ¹	Not Specified	Not Specified
35	8	C1:7	Reserved	AF4
31	16	C1:3	Reserved	W3
27	24	C0:7	Reserved	AC1
23	32	C0:3	Reserved	X6
34	10	C1:6	RS1#	AH22
30	18	C1:2	RS0#	AH26
26	26	C0:6	DEFER	AN19
22	34	C0:2	HITM#	AL23
33	12	C1:5	Reserved	V4
29	20	C1:1	REQ4#	AL17
25	28	C0:5	HIT#	AL25
21	36	C0:1	TRDY#	AN25
32	14	C1:4	REQ3#	AL19
28	22	C1:0	REQ2#	AH18
24	30	C0:4	REQ1#	AH16
20	38	C0:0	REQ0#	AK18

¹ Possible qualifier line

² Signal is active low

Table 1–10: CPU to Mictor connections for Mictor A pins (Low)

Tektronix Mictor A pin number	AMP Mictor A pin number	LA channel	Processor pin name	Processor pin number
4	7	A3:7	A31#	AD4
5	9	A3:6	A30#	AA3
6	11	A3:5	A29#	Z4
7	13	A3:4	A28#	AK6
8	15	A3:3	A27#	AA1
9	17	A3:2	A26#	Y3
10	19	A3:1	A25#	AF6
11	21	A3:0	A24#	AB4
12	23	A2:7	A23#	AB6
13	25	A2:6	A22#	AE3
14	27	A2:5	A21#	AJ1
15	29	A2:4	A20#	AC3
16	31	A2:3	A19#	AG3
17	33	A2:2	A18#	Z6
18	35	A2:1	A17#	AE1
19	37	A2:0	A16#	AN7
35	8	A1:7	A15#	AL5
34	10	A1:6	A14#	AK14
33	12	A1:5	A13#	AL7
32	14	A1:4	A12#	AN5
31	16	A1:3	A11#	AK10
30	18	A1:2	A10#	AH6
29	20	A1:1	A9#	AL9
28	22	A1:0	A8#	AH10
27	24	A0:7	A7#	AL15
26	26	A0:6	A6#	AN9
25	28	A0:5	A5#	AH8
24	30	A0:4	A4#	AH12
23	32	A0:3	Derived	Derived
22	34	A0:2	Derived	Derived
21	36	A0:1	Derived	Derived
20	38	A0:0	Derived	Derived

Table 1-11: CPU to Mictor connections for Mictor D pins (Low)

Tektronix Mictor A pin number	AMP Mictor A pin number	LA channel	Processor signal name	Processor signal name
4	7	D3:7	Derived	Derived
5	9	D3:6	Derived	Derived
6	11	D3:5	Derived	Derived
7	13	D3:4	Derived	Derived
8	15	D3:3	TDO	AN37
9	17	D3:2	THERMTRIP#	AH28
10	19	D3:1	LINT0/INTR	M36
11	21	D3:0	PICD0	J35
12	23	D2:7	PREQ#	J37
13	25	D2:6	BPM0#	C35
14	27	D2:5	BCLK	W37
15	29	D2:4	STPCLK#	AG35
16	31	D2:3	TCK	AL33
17	33	D2:2	TDI	AM35
18	35	D2:1	A20M#	AE33
19	37	D2:0	BP3#	E37
35	8	D1:7	IERR#	AE35
34	10	D1:6	FERR#	AC35
33	12	D1:5	IGNNE#	AG37
32	14	D1:4	TMS	AK32
31	16	D1:3	TRST#	AN33
30	18	D1:2	LINT1/NM1	L37
29	20	D1:1	PICCLK#	J33
28	22	D1:0	BP2#	G33
27	24	D0:7	PICD1	L35
26	26	D0:6	BPM1#	E35
25	28	D0:5	Reserved	Y1
24	30	D0:4	SMI#	AJ35
23	32	D0:3	Reserved	B36
22	34	D0:2	Reserved	E31
21	36	D0:1	Reserved	E29
20	38	D0:0	Not Specified	Not Specified



Specifications

Specifications

This chapter contains information regarding the specifications of the TMS PGA PGA370 microprocessor hardware support.

Circuit Description

The following is a description of Signal Probing, Bus Tracking Logic, and Debug circuitry.

Debug Port

The PGA370 probe adapter provides a connection point for a Debug Port. In addition to the standard debug port, the probe adapter contains circuitry to terminate the debug control and data signals to their appropriate voltage levels. The debug circuitry on the probe adapter supports both 1.5 V CMOS I/O and 2.5V CMOS I/O. The debug circuitry on the probe adapter uses the VCC_CMOS signal on the microprocessor to detect the CMOS I/O voltage level.

When using the debug port on the probe adapter, a 363-pin sacrificial socket must be installed on the system under test to isolate the debug signals between the system under test and the microprocessor. Isolating the debug signals allows the probe adapter to control the debug signals on the local CPU.

The debug circuitry on the probe adapter can only control the debug signals when an debug probe cable is plugged into the debug port on the logic board. When the cable is removed, all debug data and control lines are tristated.

Probe Adapter Loading Diagrams

Figures 2–1 through 2–5 are provided for loading reference.

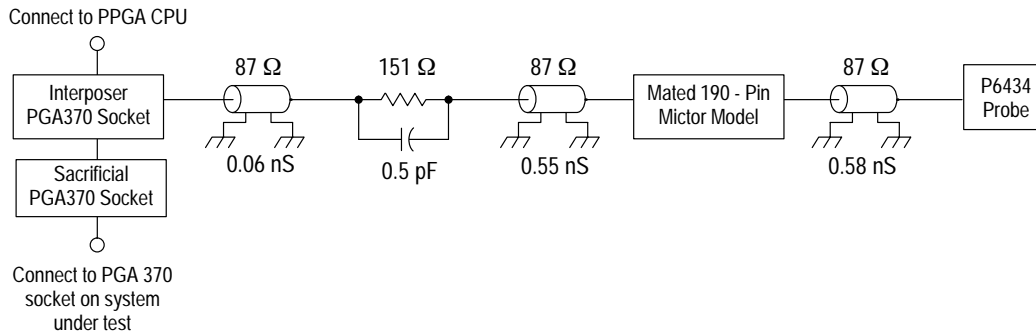

Figure 2–1: PGA370 signals without active loads

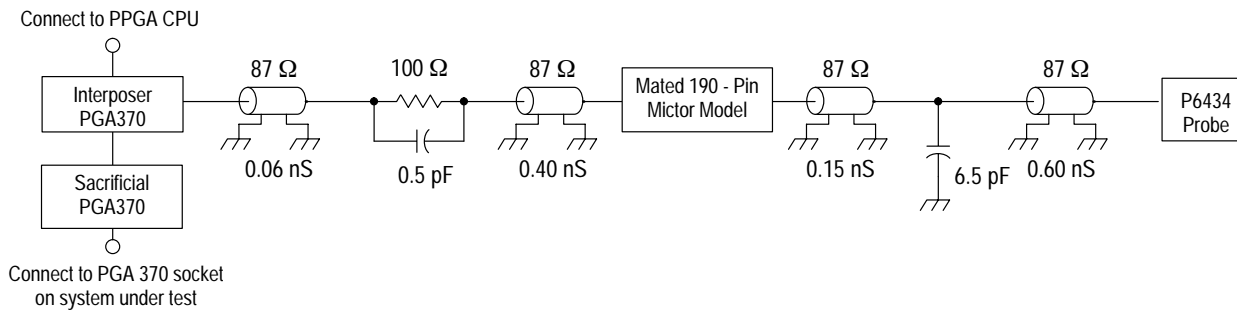

Figure 2–2: PGA370 signals with active loads

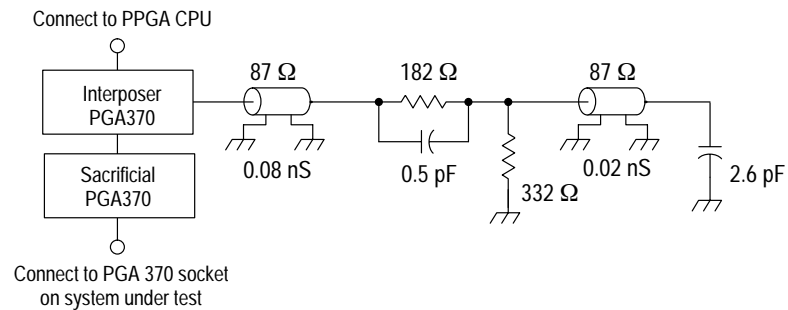

Figure 2–3: PGA370 BCLK

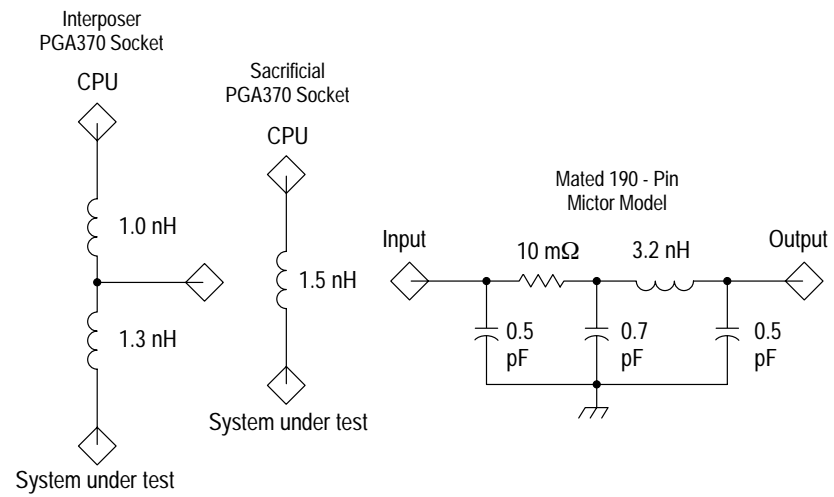

Figure 2-4: Detail of PGA370 sockets and 190-pin mictor connector.

Table 2–1 shows the values you can use to calculate characteristics of the Lossy delay lines shown in Figure 2–5, which is the equivalent circuit of the P6434 probe.

Table 2–1: Lossy delay line values

Characteristic	Value
C (capacitance)	1.58 pF per inch
L (inductance)	8.9 nH per inch
R (resistance)	.067 Ω per inch
Z_0 (impedance)	75 Ω

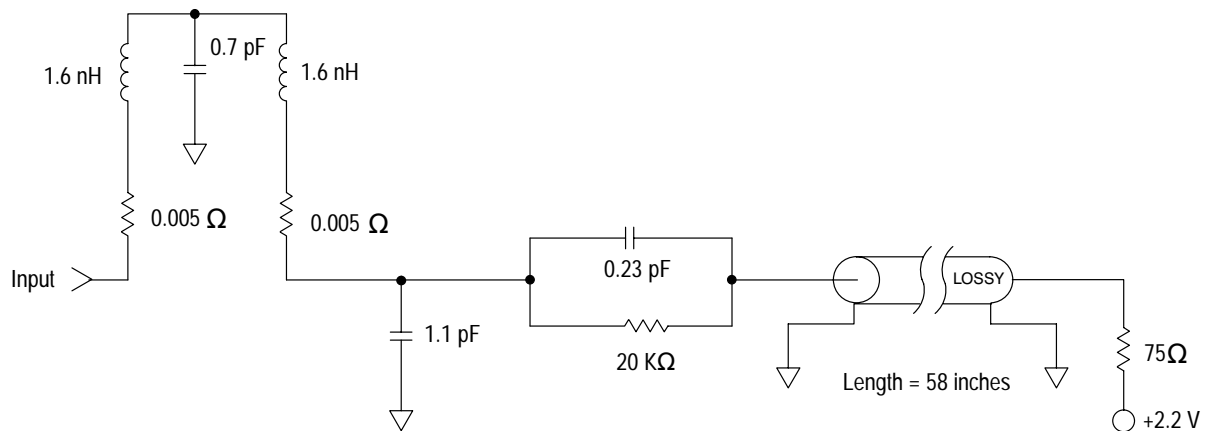

Figure 2–5: Equivalent circuit for the P6434 probe

Specification Tables

These specifications are for a probe adapter connected between a compatible Tektronix logic analyzer and a system under test. Signal voltage swing in your system under test must be at least 200 mV around the GTL+ reference voltage.

Table 2–2 lists the electrical requirements of the system under test. Table 2–3 lists the electrical requirements for the power supply that provides power to the PGA370 probe adapter. Table 2–4 lists the environmental specifications. Table 2–5 lists the BCLK timing restrictions and electrical specifications.

Table 2–2: Electrical specifications for the system under test

Characteristics	Requirements	
System under test DC power requirements		
Voltage, VCC_1.5 V	1.5 V \pm 9 %	
Current, VCC_1.5 V	I maximum 35 mA, I typical 1.8 mA	
Voltage, VREF6	1.0 V \pm 2 %	
Current, VREF6	I maximum <1 mA, I typical <1 mA	
Voltage, VCC_CMOS (1.5 V) ¹	1.5 V \pm 9 %	
Current, VCC_CMOS (1.5 V) ¹	I maximum 20 mA, I typical 0.9 mA	
Voltage, VCC_CMOS (2.5 V) ¹	2.5 V \pm 5 %	
Current, VCC_CMOS (2.5 V) ¹	I maximum 35 mA, I typical 1.4 mA	
System under test clock rate	Maximum 100 MHz	
System under test tested clock rate	Maximum 100 MHz	
Minimum setup time required, all signals	2.8 ns	
Minimum hold time required, all signals	0.2 ns	
Measured typical SUT signal loading	Specification	
	AC load	DC load
	8 pF	74GTL16622 in parallel with 20 k Ω
	BCLK	AD8009
	Signals without active loads	20 k Ω

¹ The VCC_CMOS supply voltage can be either 1.5 V or 2.5 V depending on the CMOS I/O voltage level of the target microprocessor.

Table 2–3: Electrical specifications for the AC adapter

Characteristic	Description
Input Voltage rating	90 – 265 V
Input Frequency Rating	47 – 63 Hz
Output Voltage Rating	5 V
Output Current Rating	5 V
Output Power Rating	25 W

Table 2–4: Environmental specifications

Characteristic ¹	Description
Temperature	
Maximum operating	+50° C (+122° F) ²
Minimum operating	0° C (+32° F)
Nonoperating	–55° C to +75° C (–67° to +167° F)
Humidity	10 to 95% relative humidity
Altitude	
Operating	4.5 km (15,000 ft) maximum
Nonoperating	15 km (50,000 ft) maximum
Electrostatic immunity	The probe adapter is static sensitive

¹ Designed to meet Tektronix standard 062-2847-00 class 5.

² Not to exceed microprocessor thermal considerations. Forced air cooling might be required across the CPU.

Table 2–5: BCLK timing and electrical specifications

Characteristics	Minimum	Maximum	Units	Notes
$V_{in} (lo)$		0.5	V	
$V_{in} (hi)$	2.0		V	
Duty Cycle	25	75	%	
t_{lh}		1.25	ns	Monotonically increasing
t_{hl}		1.25	ns	Monotonically decreasing

Dimensions Figure 2–6 shows the dimensions of the PGA370 probe adapter. The figure also shows the minimum vertical clearance of the high-density probe cable.

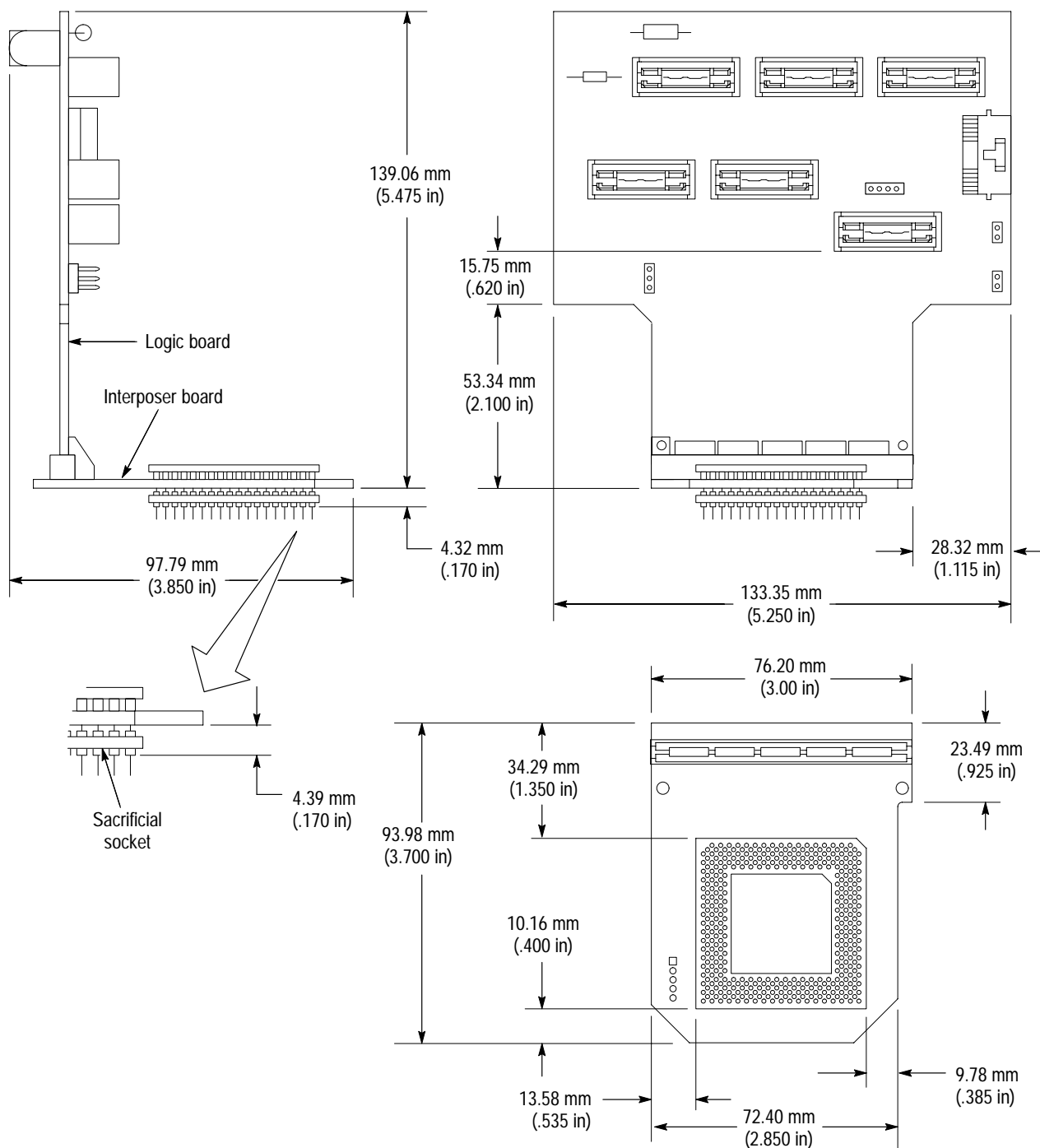

Figure 2–6: Dimensions of the PGA370 probe adapter



WARNING

The following servicing instructions are for use only by qualified personnel. To avoid injury, do not perform any servicing other than that stated in the operating instructions unless you are qualified to do so. Refer to all safety summaries before performing any service.



Maintenance

Maintenance

This section contains information on replacing the PGA370 probe-adapter fuse.

Replacing The Fuse

If the fuse on the probe adapter opens (burns out), you can replace it with a 5 A, 125 V fuse. Figure 3-1 illustrates the location of the fuse on the PGA370 probe adapter. See the *Replaceable Mechanical Parts* chapter for part descriptions.

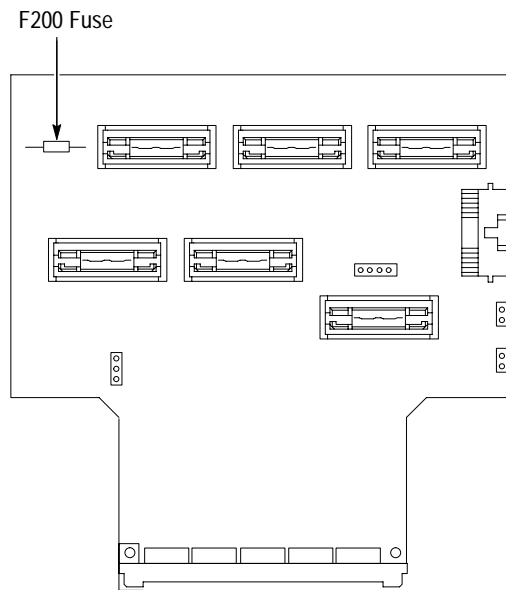

Figure 3-1: Fuse location on the PGA370 probe adapter



Replaceable Mechanical Parts

Replaceable Parts List

This chapter contains a list of the replaceable components for the TMS PGA PGA370 Hardware Support product.

Parts Ordering Information

Replacement parts are available through your local Tektronix field office or representative.

Changes to Tektronix products are sometimes made to accommodate improved components as they become available and to give you the benefit of the latest improvements. Therefore, when ordering parts, it is important to include the following information in your order:

- Part number
- Instrument type or model number
- Instrument serial number
- Instrument modification number, if applicable

If you order a part that has been replaced with a different or improved part, your local Tektronix field office or representative will contact you concerning any change in part number.

Change information, if any, is located at the rear of this manual.

Using the Replaceable Parts List

The tabular information in the Replaceable Parts List is arranged for quick retrieval. Understanding the structure and features of the list will help you find all of the information you need for ordering replacement parts. The following table describes the content of each column in the parts list.

Parts list column descriptions

Column	Column name	Description
1	Figure & index number	Items in this section are referenced by figure and index numbers to the exploded view illustrations that follow.
2	Tektronix part number	Use this part number when ordering replacement parts from Tektronix.
3 and 4	Serial number	Column three indicates the serial number at which the part was first effective. Column four indicates the serial number at which the part was discontinued. No entries indicates the part is good for all serial numbers.
5	Qty	This indicates the quantity of parts used.
6	Name & description	An item name is separated from the description by a colon (:). Because of space limitations, an item name may sometimes appear as incomplete. Use the U.S. Federal Catalog handbook H6-1 for further item name identification.
7	Mfr. code	This indicates the code of the actual manufacturer of the part.
8	Mfr. part number	This indicates the actual manufacturer's or vendor's part number.

Abbreviations Abbreviations conform to American National Standard ANSI Y1.1–1972.

Chassis Parts Chassis-mounted parts and cable assemblies are located at the end of the Replaceable Electrical Parts List.

Mfr. Code to Manufacturer Cross Index The table titled Manufacturers Cross Index shows codes, names, and addresses of manufacturers or vendors of components listed in the parts list.

Manufacturers cross index

Mfr. code	Manufacturer	Address	City, state, zip code
00779	AMP INC.	CUSTOMER SERVICE DEPT PO BOX 3608	HARRISBURG, PA 17105-3608
14310	AULT INC	7300 BOONE AVE NORTH BROOKLINE PARK	MINNEAPOLIS, MN 55428
1AW87	LEWIS SCREW CO.	4300 SOUTH RACINE AVENUE	CHICAGO, IL 60609
26742	METHODE ELECTRONICS INC	BACKPLAIN DIVISION 7444 WEST WILSON AVE	CHICAGO, IL 60656-4548
5Y400	TRIAx METAL PRODUCTS INC	1880 SW MERLO DRIVE	BEAVERTON, OR 97006
60381	PRECISION INTERCONNECT CORP.	16640 SW 72ND AVE	PORTLAND, OR 97224
61857	SAN-O INDUSTRIAL CORP	91-3 COLIN DRIVE	HOLBROOK, NY 11741
63058	BERG ELECTRONICS INC.	MCKENZIE SOCKET DIV 910 PAGE AVE	FREMONT, CA 94538-7340
80009	TEKTRONIX INC	14150 SW KARL BRAUN DR PO BOX 500	BEAVERTON, OR 97077-0001
82389	SWITCHCRAFT	DIV OF RAYTHEON 5555 N. ELSTON AVENUE	CHICAGO, IL 60630-1314
S3109	FELLER U.S. CORPORATION	72 VERONICA AVE UNIT #4	SOMERSET, NJ 08873
TK1373	PATELEC-CEM	10156 TORINO VAICENTALLO 62/456	ITALY,
TK2541	AMERICOR ELECTRONICS LTD	UNIT-H 2682 W COYLE AVE	ELK GROVE VILLAGE, IL 60007
TK2548	XEROX CORPORATION	14181 SW MILLIKAN WAY	BEAVERTON, OR 97005

Replaceable Parts List

Replaceable parts list

Fig. & index number	Tektronix part number	Serial no. effective	Serial no. discont'd	Qty	Name & description	Mfr. code	Mfr. part number
5-1-0	010-0626-00			1	ADAPTER,PROBE:100MHZ SOCKETED 370 PIN PPGA;TMS112 OPT 03	80009	010-0626-00
-1	671-4707-00			1	CIRCUIT BD ASSY:370 PIN PPGA,SOCKETED LOGIC BD,TMS112 OPT 03	80009	671-4707-00
-2	131-6610-00			1	JACK,POWER DC:PCB,MALE,RTANG,2MM PIN DIA,BRASS,SILVER PLATE,5A,	82389	RAPC722TB
-3	131-1857-00			1	CONN, HDR: PCB, MALE, STR, 1 X 36, 0.1 CTR, 0.230 MLG X 0.100 TAIL, GOLD	22526	65507-136
-4	131-4850-00			1	CONN,HDR:PCB,MALE,RTANG,2 X 15,0.05 X 0.1 CTR,0.35 H X 0.10 TAIL,CTR PLZ,LATCHING,30 GOL	00779	104069-5
-5	131-4917-00			2	CONN, HDR: PCB, MALE, STR,1 X 2, 0.1 CTR, 0.235 MLG X 0.110 TAIL, 30 GOLD, TUBE, HIGH TEMP	00779	104350-1
-6	211-0022-00			2	SCREWS,MACHINE 2-56 X 0.188,PNH,STL CD PL,POZ	05276	6151
-7	136-1340-00			1	SOCKET,PGA:PCB,CUSTOM INTERSTITIAL PGA,FEMALE,370 POS,WITH 7 PINS REMOVED,STR,OPEN CENTER,0	63058	PZA-363H-120B-3 7BL-F
-8	136-1338-00			1	SOCKET,PGA:PCB,CUSTOM INTERSTITIAL PGA,FEMALE,370 POS,STR,OPEN CENTER,0.180 L CONTACTS,30 G	63058	PGA-144H101B1-1 302-R
-9	671-4706-00			1	CIRCUIT BD ASSY370 PIN,PPGA,SOCKETED,BASE BD,;TMS112 OPT 03	80009	671-4706-00
-10	407-4677-00			2	BRACKET BOARD MOUNT,0.036 CRS	5Y400	407-4677-00
-11	131-4356-00			1	CONN,SHUNT:SHUNT/SHORTING,FEMALE,1 X 2,0.1 CTR,0.63 H,BLK,W/HANDLE,JUMPER,30 GOLD,	26742	9618-302-50
-12	131-4530-00			1	CONN,HDR:PCB,MALE,STR,1 X 3,0.1 CTR,0.230 MLG X 0.120 TAIL,30 GOLD,BD RETENTION,	00779	104344-1
-13	105-1089-00			6	LATCH ASSY:LATCH HOUSING ASSY,VERTICAL MOUNT,0.48 H X 1.24 L,W/PCB SINGLE CLIP,P6434	60381	105-1089-00
-14	131-6134-01			6	CONN,PLUG:SMD,MICTOR,PCB,FEMALE,STR,38 POS,0.025 CTR,0.245 H,GOLD,TLA7QS	00779	767054-1
-15	159-0059-00			1	FUSE,WIRE LEAD:5A,125V	61857	SPI-5A
					STANDARD ACCESSORIES		
	071-0475-01			1	MANUAL,TECH:INSTRUCTIONS,PPGA HARDWARE SUPPORT,TMSPGA,DP	TK2548	071-0475-01
	161-0104-00			1	CA ASSY,PWR:3,18 AWG,98 L,250V/10AMP,98 INCH,RTANG,IEC320,RCPT X STR,NEMA 15-5P,W/CORD GRIP,	S3109	ORDER BY DESCRIPTION
	119-5061-01			1	POWER SUPPLY:25W,5V 5A,CONCENTRIC 2MM,90-265V,47-63 HZ IEC,15X8.6X5 CM, UL,CSA, TUV,IEC,SELF	14310	SW108KA0002F01
					OPTIONAL ACCESSORIES		
	-----*			6	P6434 MASS TERMINATION PROBE, Opt 21 *	80009	ORDER BY DESCRIPTION
	161-0104-05			1	CA ASSY,PWR:3,1.0MM SQ,250V/10A,2.5 METER,RTANG,IEC320,RCPT,AUSTRALIA,SAFTEY CONTROLLED,	TK1373	161-0104-05

Replaceable parts list (cont.)

Fig. & index number	Tektronix part number	Serial no. effective	Serial no. discontinued	Qty	Name & description	Mfr. code	Mfr. part number
	161-0104-06			1	CA ASSY,PWR:3,1.0MM SQ,250V/10A,2.5 METER,RTANG,IEC320,RCPT,EUROPEAN,SAFTEY CONTROLLED,	TK1373	ORDER BY DESCRIPTION
	161-0104-07			1	CA ASSY,PWR:3,1.0MM SQ,240V/10A,2.5 METER,RTANG,IEC320,RCPT X 13A,FUSED,UK PLUG,(13A FUSE),UK PLUG,(13A FUSE),UNITED KINGDOM,SAFTEY CONTROL	TK2541	ORDER BY DESCRIPTION
	161-0167-00			1	CA ASSY,PWR:3,0.75MM SQ,250V/10A,2.5 METER,RTANG,IEC320,RCPT,SWISS,NO CORD GRIP,SAFTEY CONTR	S3109	ORDER BY DESCRIPTION

* Check the P6434 manual for detailed replaceable part number information.

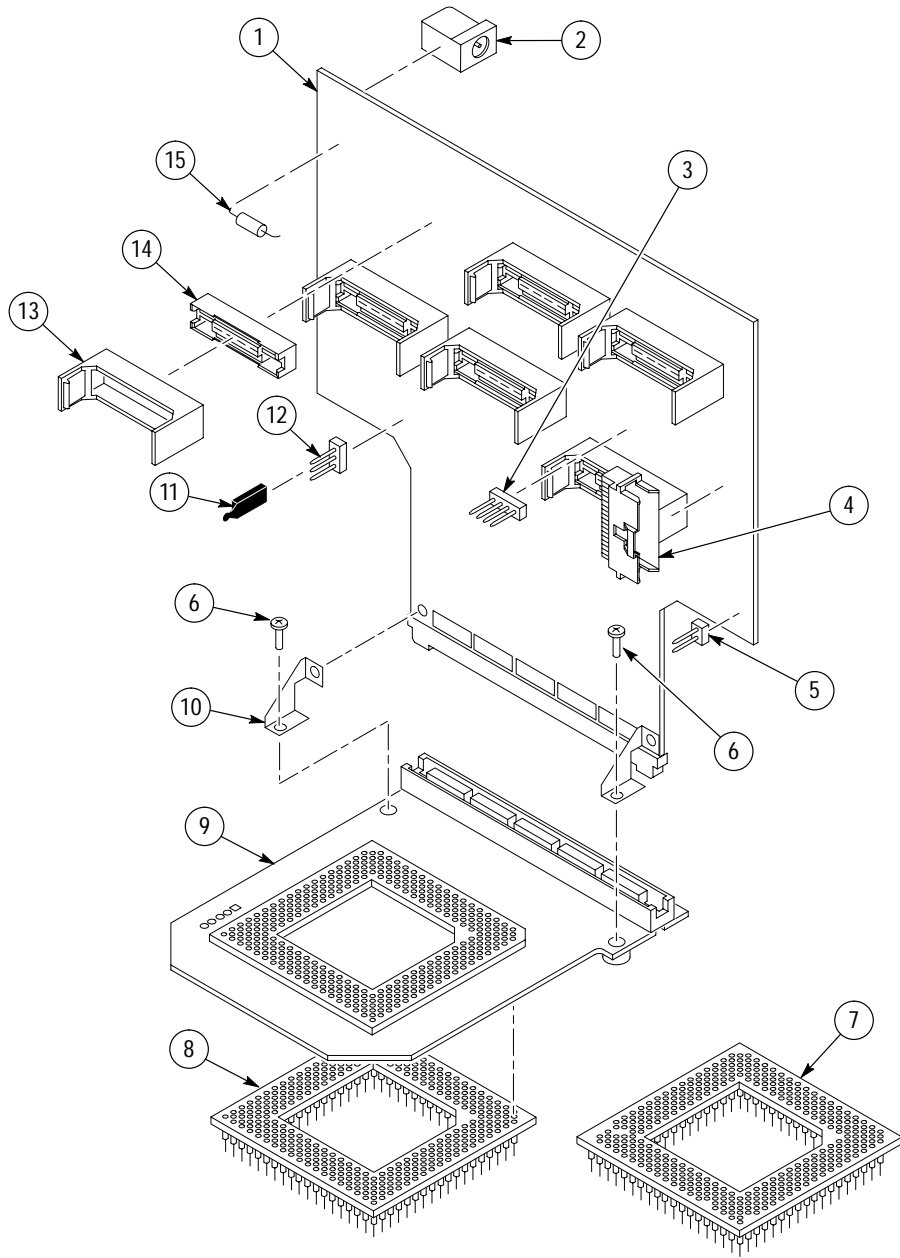

Figure 4-1: PGA370 probe adapter exploded view



Index

Index

Numbers

40 MHz system under test, 1–6

A

about this manual set, vii

AC adapter, 2–6

acquiring data, below 40 MHz, 1–6

Alternate Connections

 APIC bus support, 1–12

 Debug Port, 1–12

 Test Points, 1–14

APIC, 1–12

APIC bus support, logic analyzer configuration, 1–2

application, logic analyzer configuration, 1–2

Assembling Probe Adapter, 1–4

B

BCLK, 1–2

C

clock rate, 1–2

connections

 CPU to Mictor, 1–17

 probe adapter to SUT, 1–7

cooling requirements, 1–2

CPU to Mictor connections, 1–17

D

Debug Port. *See* Alternate Connections

definitions

 HI module, vii

 information on basic operations, vii

 LO module, vii

 module, vii

dimensions, probe adapter, PGA370, 2–7

disassembler, logic analyzer configuration, 1–2

E

electrical specifications, 2–1, 2–5

 AC adapter, 2–6

 BCKL timing, 2–6

 clock rate, 2–5

 hold time, 2–5

 power requirements, 2–5

 setup time, 2–5

 signal loading, 2–5

 tested clock rate, 2–5

environmental specifications, 2–6

 altitude, 2–6

 electrostatic immunity, 2–6

 humidity, 2–6

 temperature, 2–6

F

fuse, replacing, 3–1

H

HI module, definition, vii

I

installing hardware. *See* Alternate Connections

ITP bus support, logic analyzer configuration, 1–2

J

jumpers

 MFG_TEST, 1–6

 timing, 1–6

L

LO module, definition, vii

loading, 2–5

logic analyzer

 configuration for disassembler, 1–2

 configuration for the application, 1–2

M

manual

 conventions, vii

 how to use the set, vii

MFG_TEST pins, 1–6

Mictor to CPU connections, 1–17

module, definition, vii

P

P6434 probes, labeling, 1–3

power, for the probe adapter

 applying, 1–14

 removing, 1–15

power adapter, 1–14

power jack, 1–15

probe adapter

 clearance, dimensions, PGA370, 2–7

 configuring, 1–6

 Connecting the logic Analyzer, 1–7

 hardware description, 1–1

 jumper positions, 1–6

R

replacing the fuse, 3–1

requirements

 cooling, 1–2

 forced air cooling, 1–2

Signal Supported, 1–3

System under Test, 1–2

restrictions, 1–2

 BCLK, 1–2

S

service information, 3–1

signal loading, 2–5

Signal Supported, 1–3

signals, active low sign, vii

sockets, 370 pin or 363 pin, 1–8

specifications, 2–1

 electrical, 2–1, 2–5

 environmental, 2–6

 mechanical (dimensions), PGA370, 2–7

System Under Test power, 1–2

T

terminology, vii

Test Points. *See* Alternate Connections

TIMING/NORMAL jumper, 1–6